



WL110

Wheel loader

Productivity in a new dimension

The largest machine in the compact wheel loader segment by Wacker Neuson: the wheel loader WL110. In the 1,8 m³ class, the machine is impressive in particular for its performance, which is demonstrated by its high tipping load and pushing power. Thanks to the large bucket capacity and high operating weight, the wheel loader is ideally suited for heavy but safe materials handling. The engine and the work hydraulics are designed for productivity, making the machine an efficient helper when it comes to safely and comfortably moving large volumes of material.

Highlights

- Eco Speed Pro: continuously variable hydrostatic transmission
- {30/40 km/h}{18.64/24.85 mph} speed
- Automatic air-conditioning system
- Clear 7-inch digital display
- Joystick console spring-mounted on the operator's seat

Technical Data

Hydraulic

Operating pressure	250.0 bar
Flow rate	150.0 l/min
Flow rate max.	150.0 l/min
Tank capacity	125.0 l

Mechanical - Output Details

Travel speed	20.0 km/h
Travel speed (Option)	40.0 km/h

Mechanical Details

Length	6,500.0 mm
Width	2,390.0 mm
Height	3,060.0 mm
Operating weight	10,410.0 kg
Payload	3,337.0 kg
Tip Load	6,674.0 kg
Bucket capacity	1.80 m ³
Bucket capacity heaped	1.80 m ³

Engine

Maximum torque	500.0 Nm
----------------	----------

Starter battery Voltage	12.0 V
Battery capacity (nom. value)	185.0 Ah

Operating Fluids

Oil volume	11.000 l
Cooling fluid volume	28.0 l
Hydraulic fluid volume	240.0 l
Tank capacity AdBlue® / DEF	12.0 l
Fuel Tank capacity	140.0 l

Chassis

Turning radius	2,450.0 mm
Steering angle max.	40
Brake	Surge brake
axle	Planetary axle
drive unit	Hydrostatic
hydraulikpump	Displacement pump
Operating pressure	250.0 bar
Flow rate	150.0 l/min
tires	500/70 R24

Dimensions

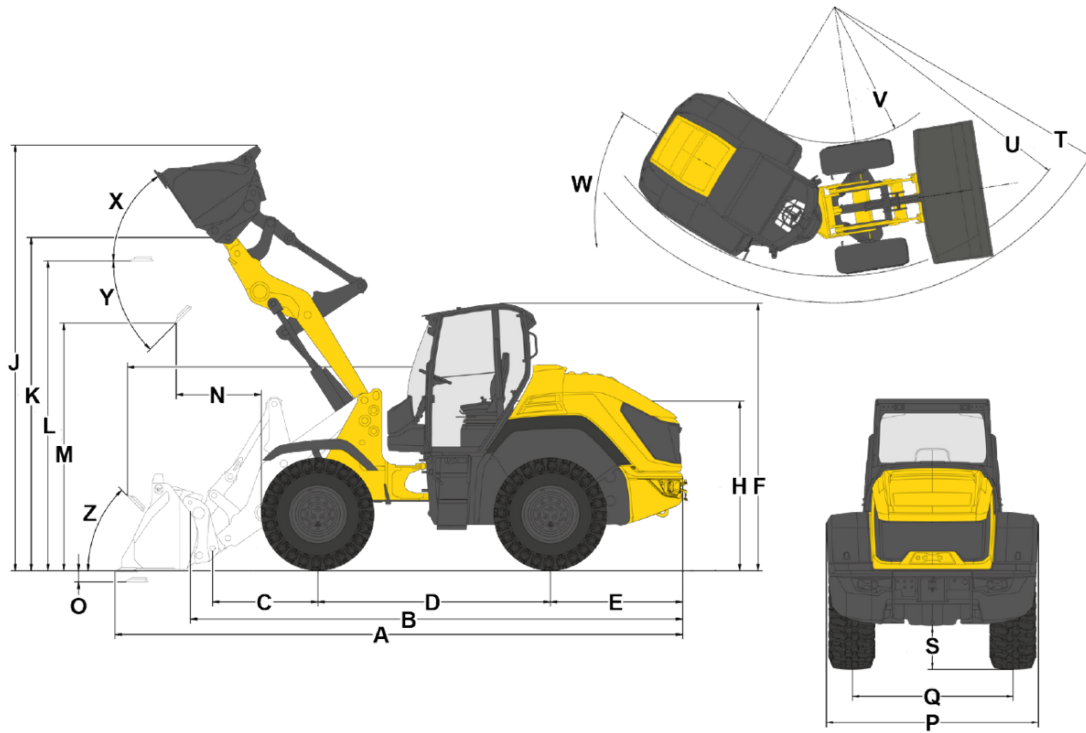

A	Total length	6,470 mm
B	Total length without bucket	5,610 mm
C	Bucket pivot point (to center of axle)	1,200 mm
D	Wheel base	2,660 mm
E	Rear overhang	1,520 mm
F	Height with cab	3,060 mm
H	Seat height	1,940 mm
J	Total working height	4,780 mm
K	Bucket pivot point (max. lift height)	3,820 mm
L	Load-over height	3,550 mm
M	Dumping height	2,860 mm
N	Reach (at M)	970 mm
O	Digging depth	136 mm
P	Total width	2,390 mm
Q	Track width	1,820 mm
S	Ground clearance	500 mm
T	Maximum radius	5,370 mm
U	Radius on the outer edge	4,900 mm
V	Inner radius	2,450 mm
W	Articulation angle	40 °
X	Rollback angle at max. lift height	61 °
Y	Dumping angle	45 °
Z	Rollback angle on ground	45 °