



## DW15e

### Electric wheel dumper

The electric dumper with all wheel drive system

The DW15e is the first fully electric-powered wheel dumper ex works, offering many additional application uses. The clearly laid-out display with charge level display and two separate engines for drive system and hydraulics ensure maximum efficiency and operating comfort. Charged overnight, it can be used again immediately the next workday, fully ready for operation without performance restrictions as compared with conventional wheel dumpers. 100% emission-free work protects the environment and the operator alike. The high service intervals and maintenance-free battery round off the perfect cost-benefit ratio.

### Highlights

- Electric drive system
- Chargeable at a normal 220 V socket
- Unlimited performance
- Very low noise pollution

### Technical Data

#### Hydraulic

Operating pressure	178.0 bar
hydraulikpump	ZRP
Flow rate	17.0 l/min
Tank capacity	20.0 l

#### Mechanical - Output Details

Gradeability	46.0 %
Speed max.	6,000.0 1/min
Travel speed	15.0 km/h

#### Mechanical Details

Length	3,357.0 mm
Width	1,322.0 mm
Height	3,038.0 mm
Weight	1,950.00 kg
Gross vehicular weight	3,525.0 kg
Payload	1,500.0 kg
Skip capacity levelled	650.0 l
Skip capacity heaped	800.0 l
Skip capacity waterlevel	420.0 l
Pendulum angle	15.0 °
Axle load Front	1,880.0 kg

Axle load Rear	1,700.0 kg
Operating weight (min.-max.)	1,966.0 - 2,025.0 kg

#### Motor

Engine type	Asynchronous motor
Effective power	15.00 KW
Nominal torque	30.0 Nm
Nominal voltage	48.0 V
Nominal Engine speed	2,150.0 1/min

#### Environment Data

Sound power LWA, guaranteed	91.0 dB(A)
-----------------------------	------------

#### Electrical System

Charging Time	8.0 h
Type of battery	GEL

#### Chassis

Turning radius	3,650.0 mm
Articulation angle	33.0 °
Brake	Parking brake 4R
hydraulikpump	Gear pump
Operating pressure	140.0 bar
Flow rate	10.0 l/min
Steering	hydraulics

tires

10.00/75-15.3 8PR 106 A8

■ **Shipping and Storage**

Shipping weight	1,890.0 kg
-----------------	------------

## Dimensions

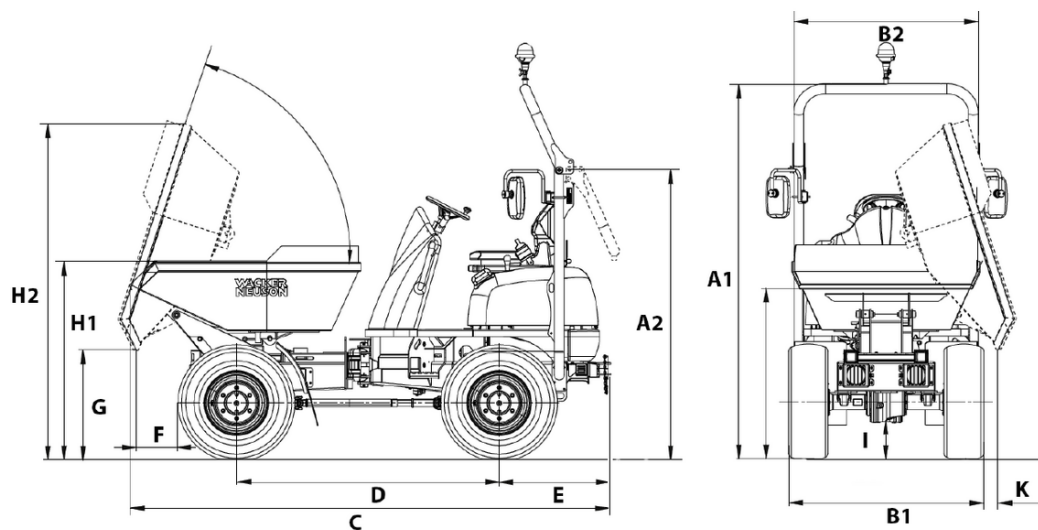

A1	Height ROPS	2,535 mm
A2	Height of ROPS tilted	1,956 mm
B1	Width of vehicle	1,304 mm
B2	Width of skip	1,198 mm
C	Total length ROPS	3,300 mm
	Total length ROPS tilted	3,357 mm
D	Wheel base	1,755 mm
E	Rear overhang	746 mm
F	Dumping width	375 mm
G	Dumping height max.	445 mm
	Dumping height max., high tip skip raised	1,516 mm
H1	Skip height	1,408 mm
H2	Skip height tilted	1,966 mm
	Skip height tilted, high tip skip raised	3,038 mm
I	Ground clearance	252 mm