



EZ36

Tracked Zero Tail Excavator

Compact design and high performance

Get in and start working – with the EZ36, performance meets maximum efficiency. This zero tail excavator is ideal if compact dimensions are needed. Minimal rear overhang makes working along walls and other obstacles an easy task. The machine features intuitive operation using a joystick, display and jog dial, as well as a comfortable working environment. This leaves the operator in full control of the application. Configurable to meet a customer's requirements, the EZ36 offers dealer-installed options, including a hydraulic thumb and rotating beacon.

Highlights

- Comfortable, fully glazed cab
- Intuitive operating concept
- Optimized drive concept
- VDS Vertical Digging System
- Zero Tail

Technical Data

Hydraulic

Operating pressure	240.0 bar
hydraulikpump	Axial piston and 2 gear pumps
Flow rate max.	120.0 l/min

Mechanical - Output Details

Nominal Engine speed	2,400.0 1/min
Travel speed	4.7 km/h

Mechanical Details

Length	5,508.0 mm
Width	1,750.0 mm
Height	2,711.0 mm
Operating weight (min.-max.)	3,718.0 - 4,945.0 kg
Digging depth (max.)	3,497.0 mm

Engine

Cooling	Water-cooling
Engine type	Diesel engine
Cylinder	3.0

Cylinder capacity	1,642.0 cm ³
Effective power	18.2 KW
Nominal Engine speed	2,400.0 1/min
Exhaust-gas limit	EU Stage V
Battery capacity (nom. value)	71.0 Ah
Manufacturer	Yanmar
Engine designation	3TNV88

Environment Data

Sound power LWA, guaranteed	94.0 dB(A)
-----------------------------	------------

Operating Fluids

Oil volume	6.700 l
Cooling fluid volume	5.0 l
Hydraulic fluid volume	61.5 l

Chassis

drive unit	Axialpistonmotor with RGU
------------	---------------------------

Shipping and Storage

Shipping weight	3,529.0 kg
-----------------	------------

Dimensions

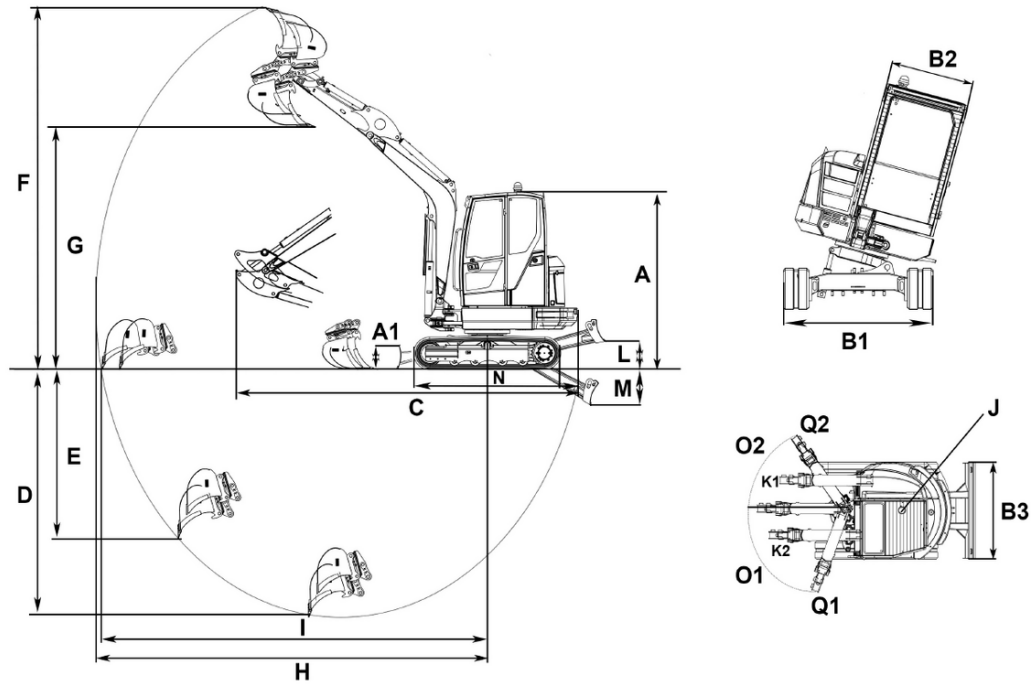

A	Height with cab	2,491 mm
A1	Height of dozer blade	357 mm
A	Total height with rotating beacon	2,630 mm
B1	Width of cab	980 mm
B2	Width travel gear	1,750 mm
B3	Width of dozer blade	1,750 mm
C	Transport length	5,503 mm
D	Digging depth max., short shovel arm	3,247 mm
	Digging depth max., long shovel arm	3,497 mm
E	Piercing depth max., short shovel arm	2,123 mm
	Piercing depth max., long shovel arm	2,360 mm
F	Piercing height max., short shovel arm	4,925 mm
	Piercing height max., long shovel arm	5,082 mm
G	Dumping height max., short shovel arm	3,336 mm
	Dumping height max., long shovel arm	3,489 mm
H	Digging radius max., short shovel arm	5,298 mm
	Digging radius max., long shovel arm	5,582 mm
I	Max. reach at ground level (short shovel arm)	5,391 mm
	Max. reach at ground level (long shovel arm)	5,641 mm
J	Tail swing radius	933 mm
K1	Boom offset max. (to center of bucket right side)	680 mm
K2	Boom offset max. (to center of bucket left side)	650 mm
L	Stacking height max. (dozer blade above surface)	393 mm
M	Digging depth max. (dozer blade below surface)	505 mm
N	Length travel drive	2,062 mm
O1	Max. swivel angle (arm system to the left)	70 °
O2	Max. swivel angle (arm system to the right)	45 °
Q1	Boom swing radius right	55 °
Q2	Boom swing radius left	70 °